

MasterSheet

019 0137

Revision 04/04/05



Complete Car Audio
Installation Instructions
CRUTCHFIELD™

**2000-
Ford Taurus
Mercury Sable
Sedan**

IMPORTANT

Before starting, compare items on your invoice with items received. Carefully check through packaging material. If any item is missing, please call **Crutchfield Technical Service at 1-800-955-9094**.

Although reasonable attempts are made to verify the accuracy of the information contained in this MasterSheet, it is presented without warranties or guarantees of any type due to the constantly changing nature of this type of information and running changes in vehicle production. Any person or entity using this information does so at his or its own risk. If you find our instructions are different from your vehicle, or if you have questions, do not continue with your installation. Contact our toll-free technical support for assistance.











* 0 0 0 0 1 9 0 1 3 7 *

Inside...

Page

2	Factory Radio Removal	✓								
3	Installation Kit Preparation			✓		✓			✓	
4	Kit Preparation (continued)									
5	Tuner/Amp Access & Bypass						✓			
6	Wire and Cable Routing						✓			✓
7	Receiver Installation								✓	✓
8	Door Speakers		✓			✓		✓		
9	Rear Speakers (sedan)		✓	✓				✓		
10	Rear speaker (continued)									

Tools Required ▶

DIN Tools	1/4 Socket, Ratchet & Extension	1/2"	5mm	Phillips Screwdriver	Small Flat Blade Screwdriver	Panel Tool	Torx T-15 Driver	Soldering Iron and Solder	Electrical Tape
									

CRUTCHFIELD®

Copyright 2005 Crutchfield Corporation

019 0137

Factory Radio Removal

1. Set parking brake and disconnect negative battery cable to prevent any electrical short.
2. Insert **DIN tools** into holes in each side of **factory radio/climate control assembly** approximately one inch until a click is heard from each side.
Note: Do not use excessive force, so that **spring clips** are not damaged.
3. Spread tools apart slightly and pull assembly out of dash.
4. Disconnect radio wiring harness, antenna lead, climate control harnesses and remove assembly.

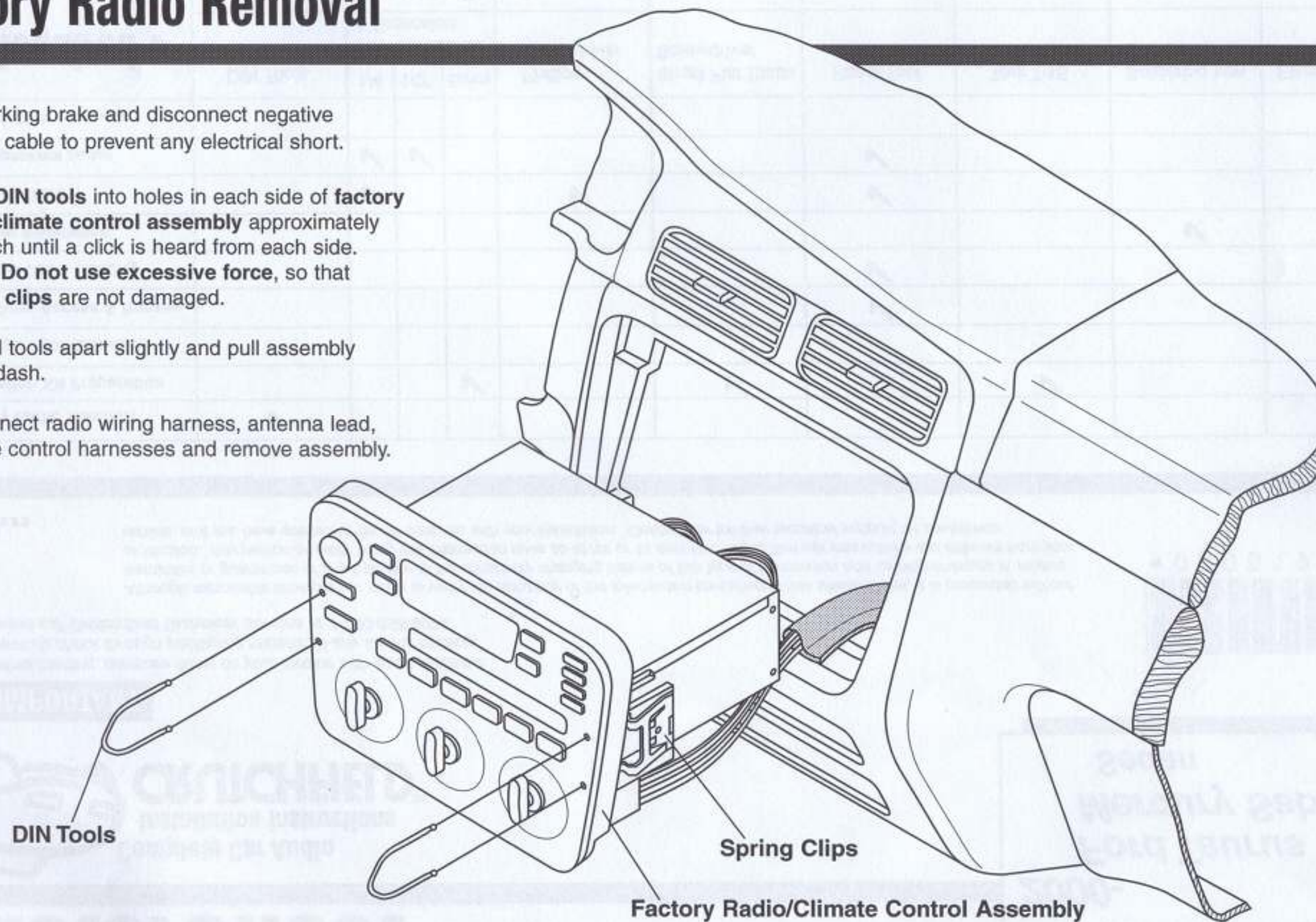

1-800-955-9094
Technical Service

CRUTCHFIELD[®]

Copyright 2005 Crutchfield Corporation

Installation Kit Preparation

- An aftermarket receiver cannot be installed in Taurus and Sable vehicles equipped with digital climate control units.

Note:

The installation kit for this vehicle is an integration package that includes a mounting bracket for the new receiver and factory climate controls. It also includes a receiver wiring harness and an antenna lead extension. To install the new receiver, the factory tuner/amp (located in the trunk of the vehicle) will be bypassed. Begin with the steps below to prepare the kit, then continue through the following pages to bypass the tuner/amp and install the new receiver.

1. Turn each **climate control knob** on factory radio/climate control assembly in the vertical position and pull off knobs (Figure 1).
2. Remove one (1) 5mm screw securing **fan switch** to rear of assembly. Rotate switch *counter-clockwise* 1/4 turn to remove switch.
3. Remove one (1) 5mm screw from **temperature control switch** and turn 1/4 turn *clockwise* to remove switch.
4. Pry out **circulation switch** from top and bottom of switch with a small flat blade screwdriver as shown (Figure 2).
5. Remove two (2) Torx T-15 screws (one on each side) from **spring clips** on sides of factory assembly. Pry up clips and slide off **mounts** (Figure 1).
6. Secure switches and spring clips to **receiver mounting bracket** in corresponding locations using hardware removed from factory assembly (Figure 3). Attach control knobs.

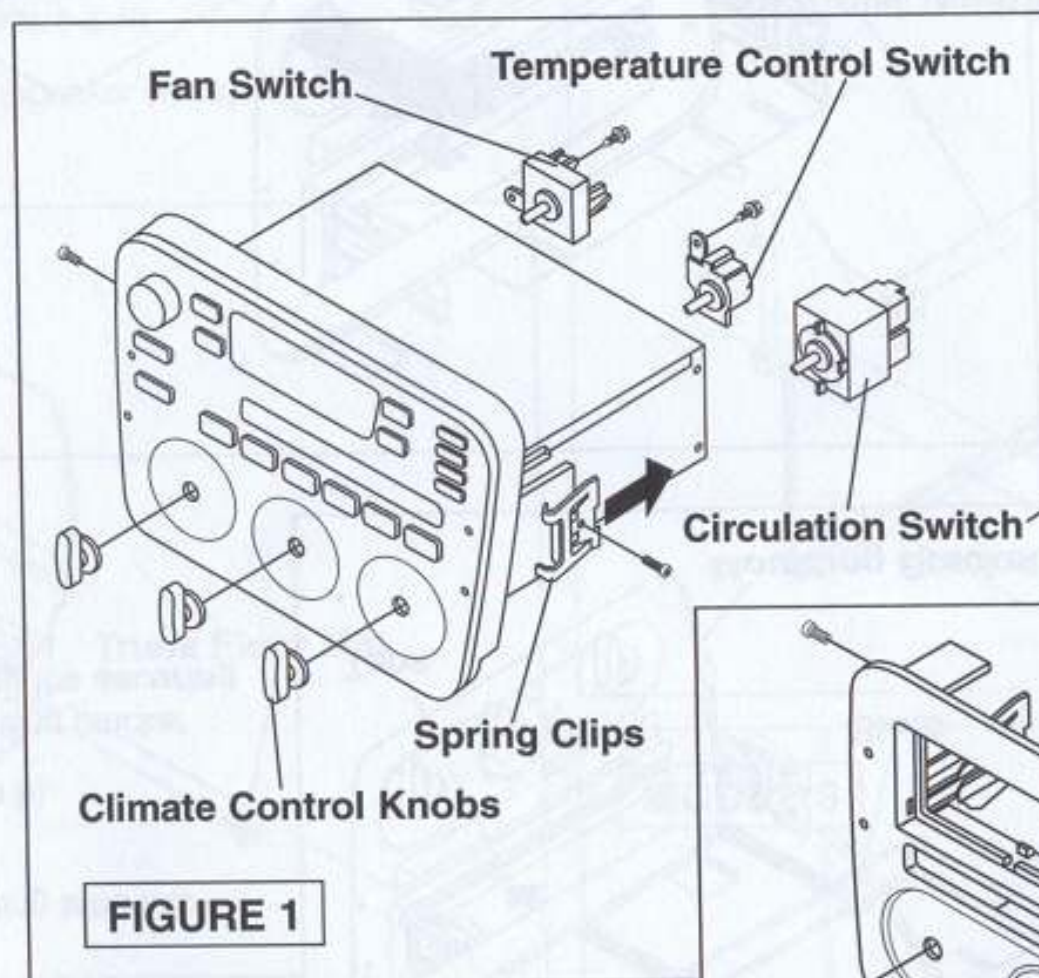

FIGURE 1

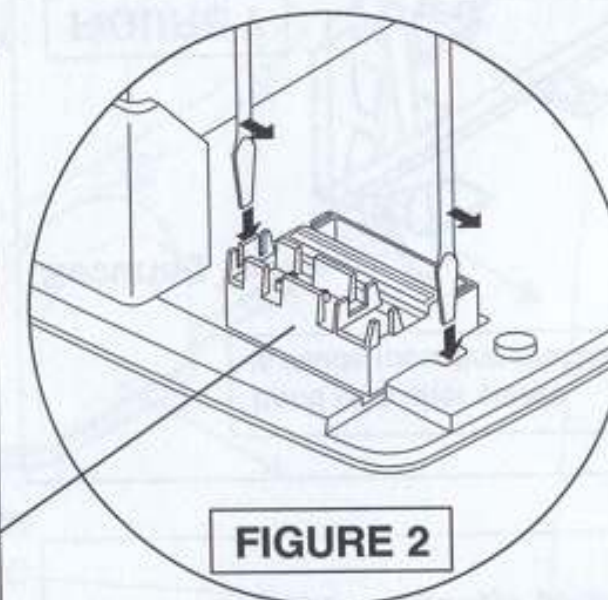

FIGURE 2

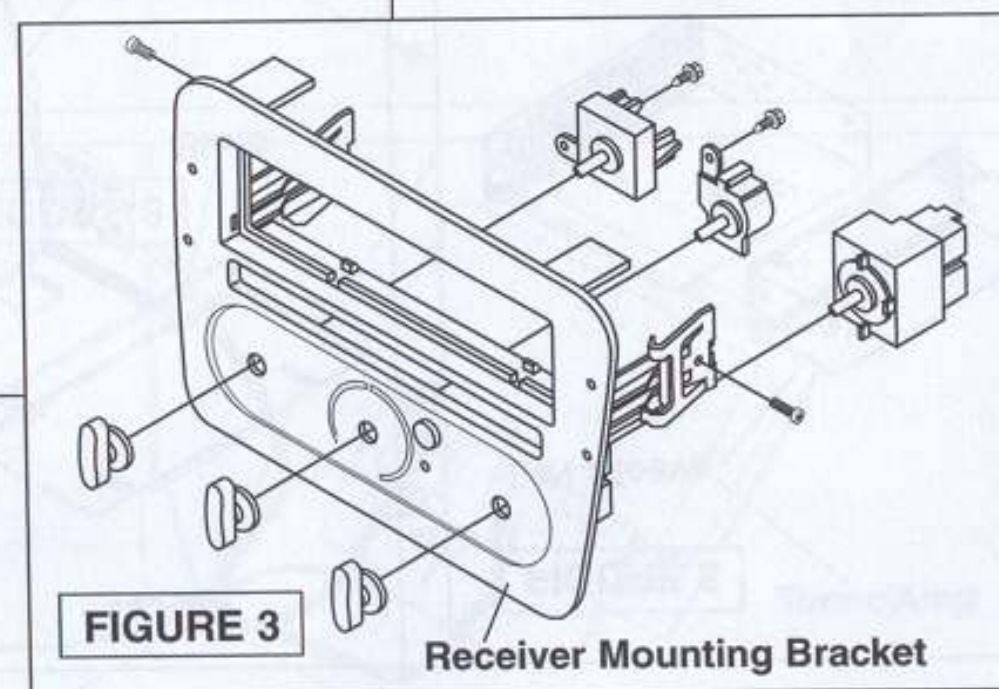

FIGURE 3

Receiver Mounting Bracket

Continued on the next page.



1-800-955-9094
Technical Service

CRUTCHFIELD[®]
Copyright 2005 Crutchfield Corporation

019 0137

Kit Preparation (continued)

7. Secure **pocket** to **mounting bracket** by inserting **tabs** into **slots** as shown (Figure 4).
8. Remove **DIN sleeve** from new receiver (Figure 5).
9. Slide DIN sleeve into opening in receiver mounting bracket (Figure 6). Secure sleeve to bracket by bending the **securing tabs** (Figure 7).
10. Slide receiver fully into sleeve (Figure 6).

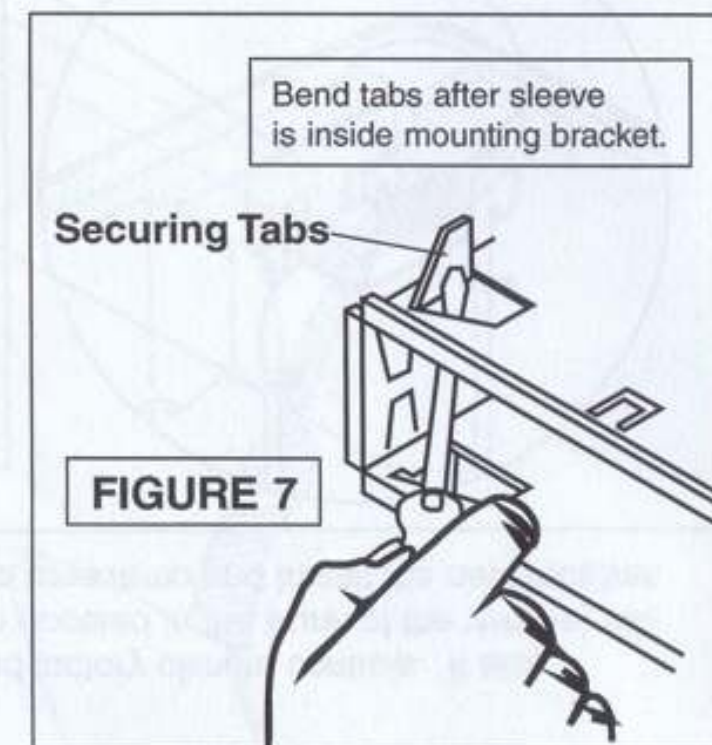
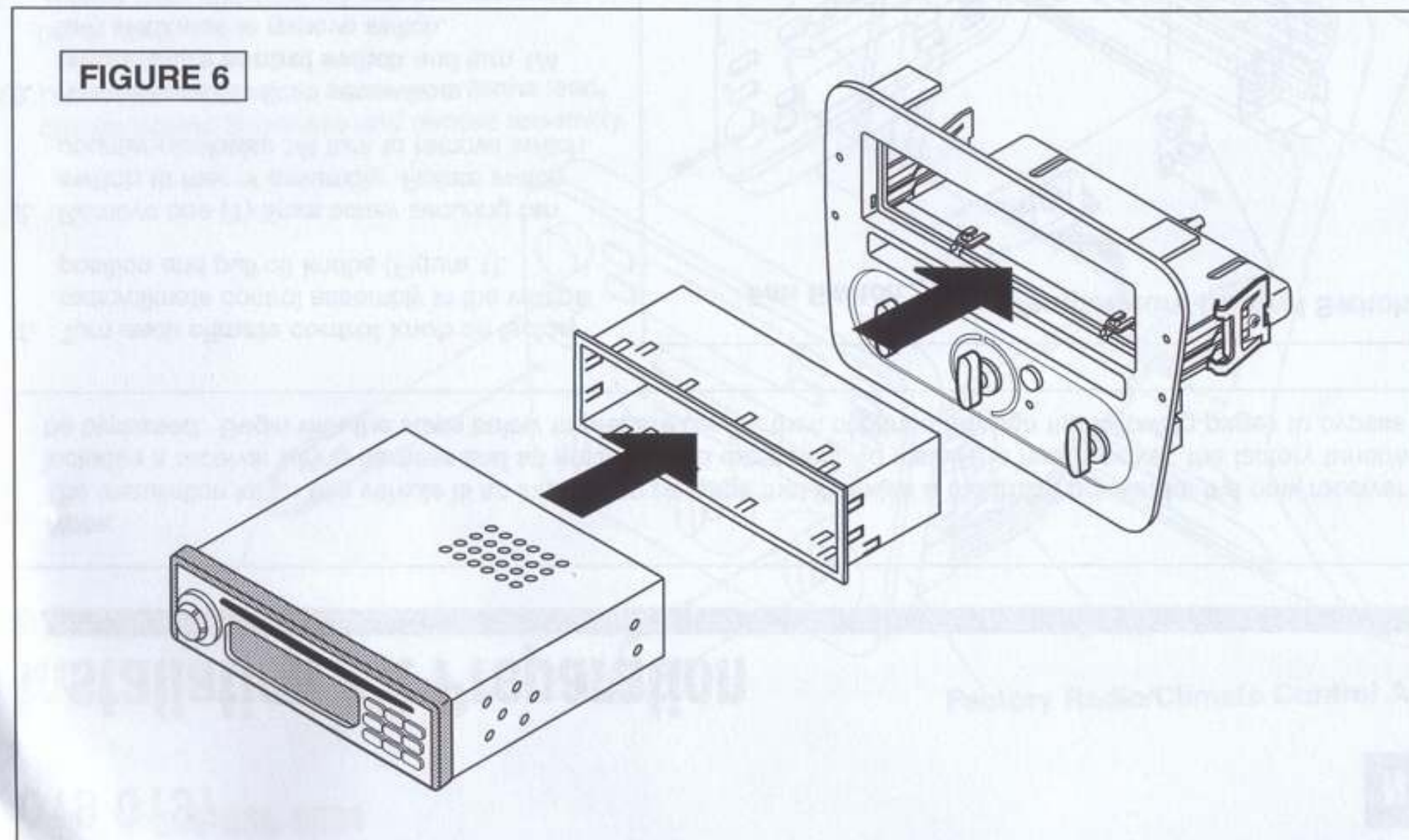
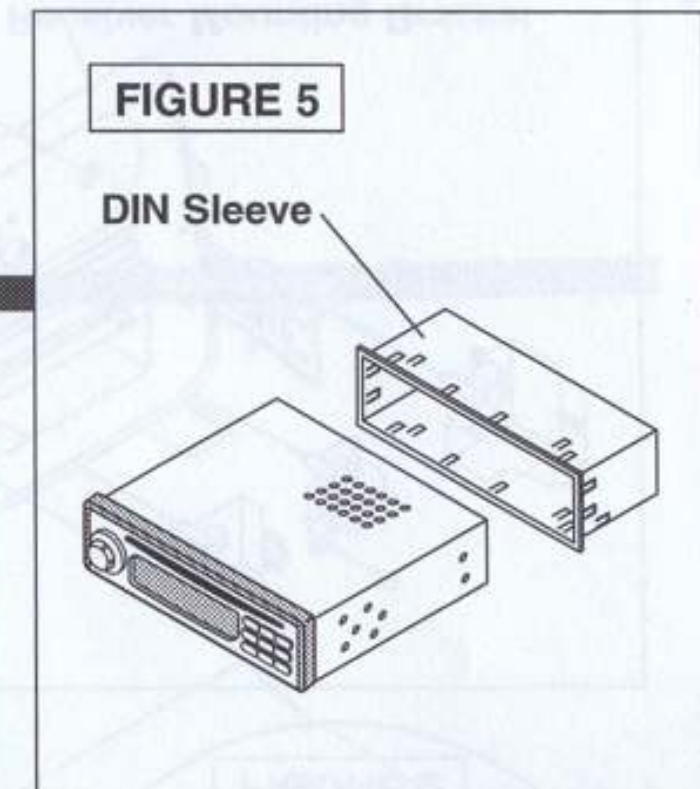
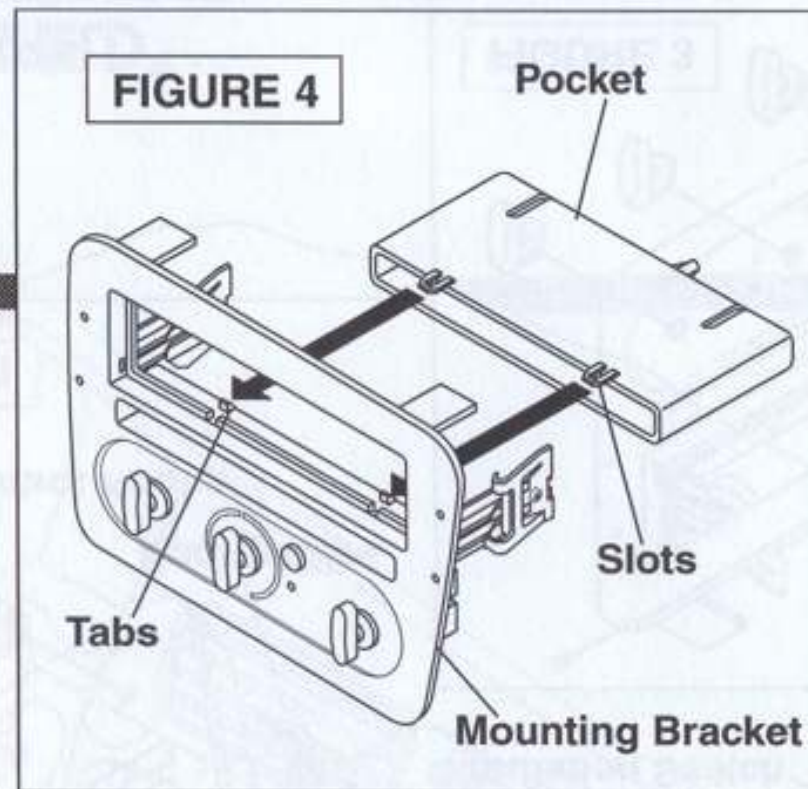

1-800-955-9094
Technical Service

CRUTCHFIELD[®]

Copyright 2005 Crutchfield Corporation

019 0137

Tuner/Amp Access & Bypass

NOTES:

Please read first

- *Inspect factory receiver harness connector in vehicle. Ensure that the wiring adaptor received from Crutchfield plugs into the vehicle's connector. If the connector is missing or incorrect, please call our Technical Service Department at 1-800-955-9094.*

1. Pull up **trunk floor mat** and remove (Figure 1).
2. Remove five (5) push-pin retaining clips from **rear trunk trimpanel** (Figure 2). Unscrew two (2) **plastic nuts** from studs (one on each end of rear trunk trimpanel). Push panel off studs and lift from trunk to remove trimpanel.
3. Remove two (2) push-pin retaining clips from **trunk trimpanel** on driver's side. Fold back trimpanel to access **tuner/amp** (Figures 1 & 3).
4. Disconnect the black wiring harness on the left (speaker wires) and disconnect antenna lead from tuner/amp (Figure 3).

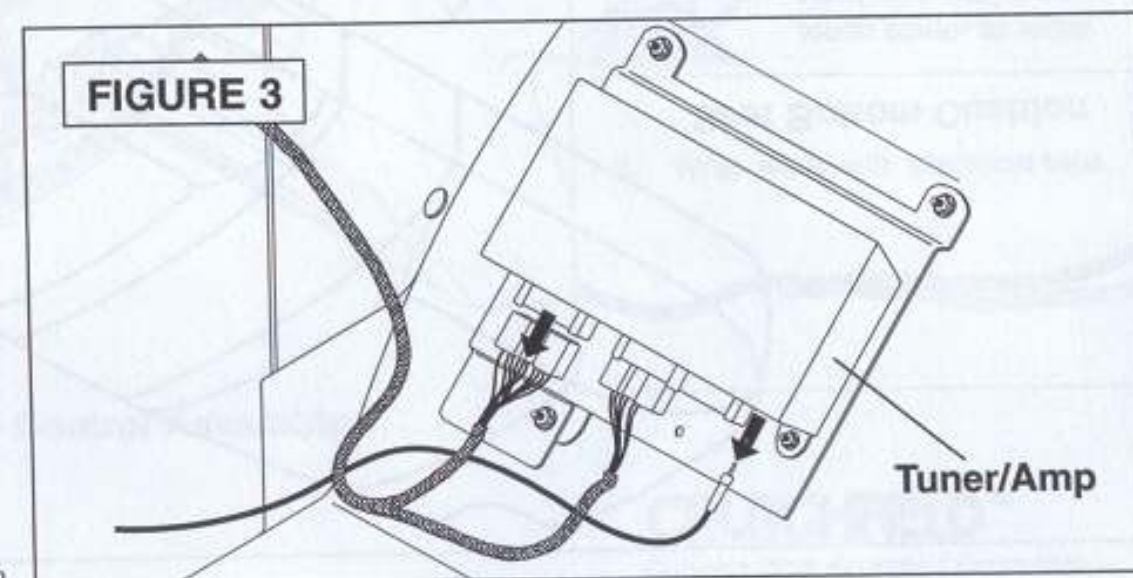
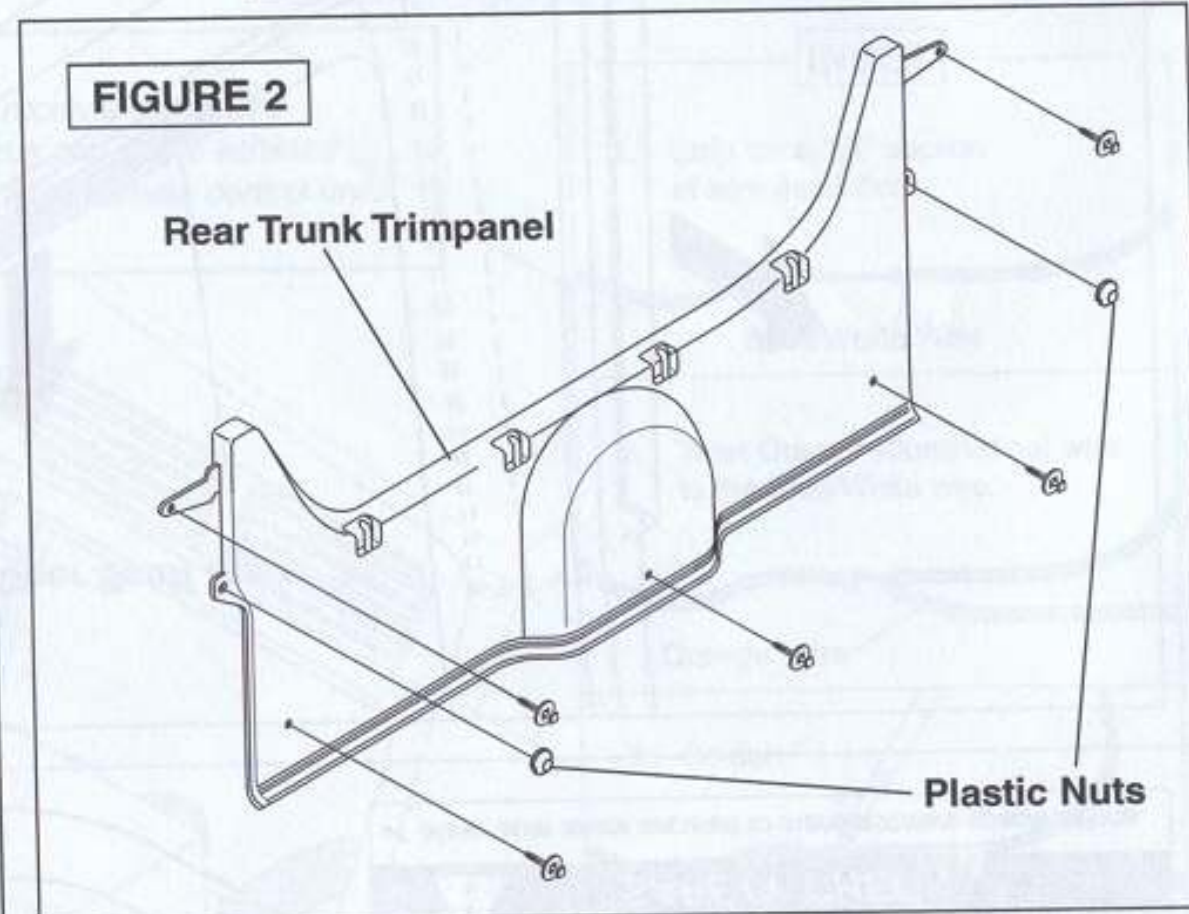
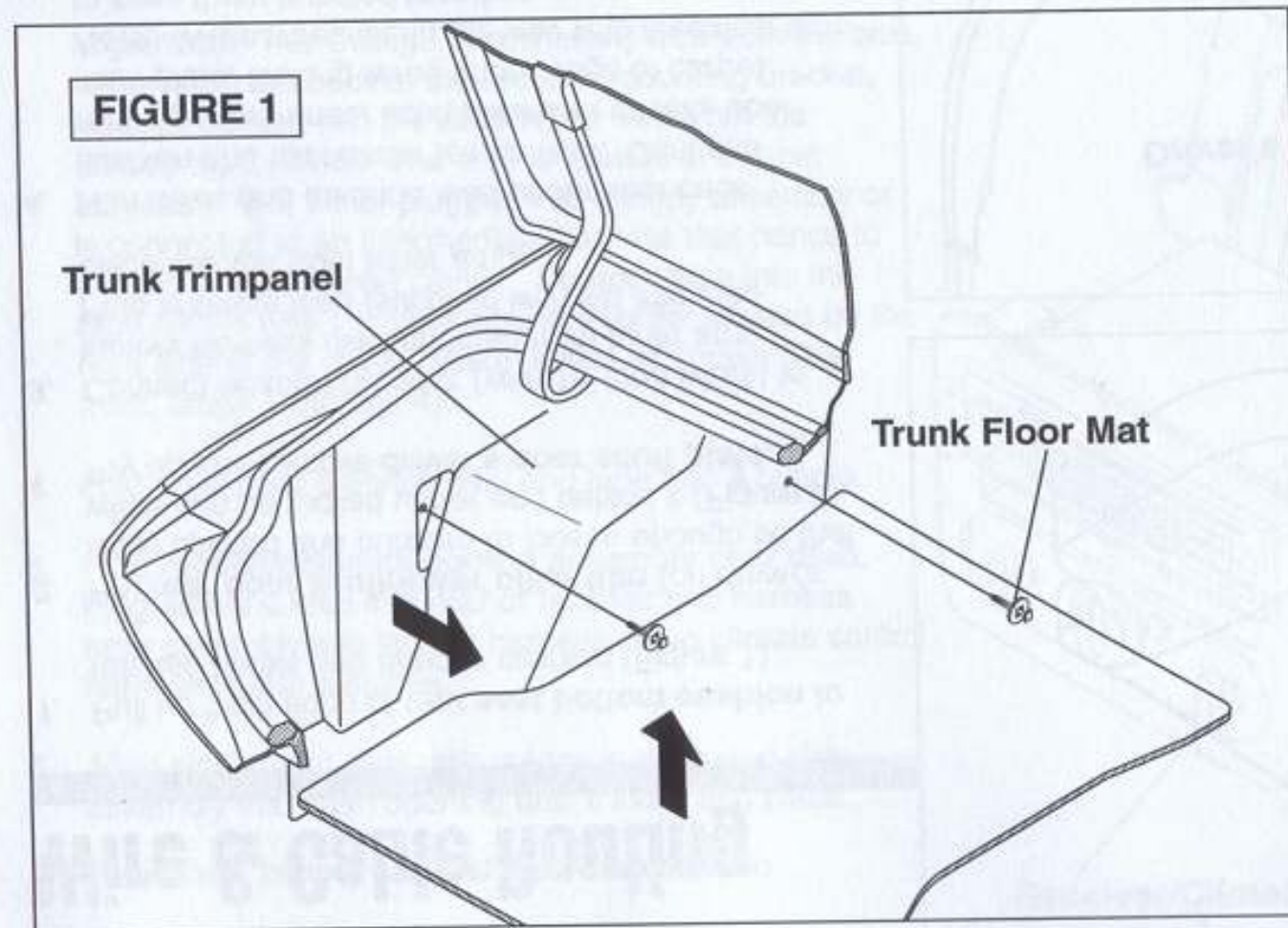

1-800-955-9094
Technical Service

CRUTCHFIELD[®]
Copyright 2005 Crutchfield Corporation

019 0137

Wire & Cable Routing

1. Pull up front edge of rear **seat bottom cushion** to release hooks and remove cushion (Figure 1).
2. Pry **rear door scuff/lower pillar trim** (on driver's side) upward and outward to loosen enough so that wires can be tucked under and behind it (Figure 2). Pry up and remove **driver's door scuff plate**.
3. Connect adaptor harness (with 18' long wires) to factory harness disconnected from tuner amp. Plug antenna lead (supplied with kit) into lead disconnected from tuner amp.
4. Run wires and antenna lead under seat back cushion and tuck under felt on floor. Continue running wires under scuff/pillar and driver's door scuff plate, tucking wires under edge of carpet. **Note:** Wrap wires along the way with electrical tape to keep them bundled together.
5. Route wires from scuff plate continuing under outer edge of floor carpet to floor area behind brake and accelerator pedals. Pull wires up behind dash and into receiver cavity. **Note:** Be sure that wires clear and do not interfere with pedals. Wrap wires with electrical tape and anchor wire bundle to a convenient location with tape or a plastic wire tie.
6. Reinstall scuff plates, rear seat and trunk panels.



1-800-955-9094

Technical Service

CRUTCHFIELD[®]

Copyright 2005 Crutchfield Corporation

FIGURE 1

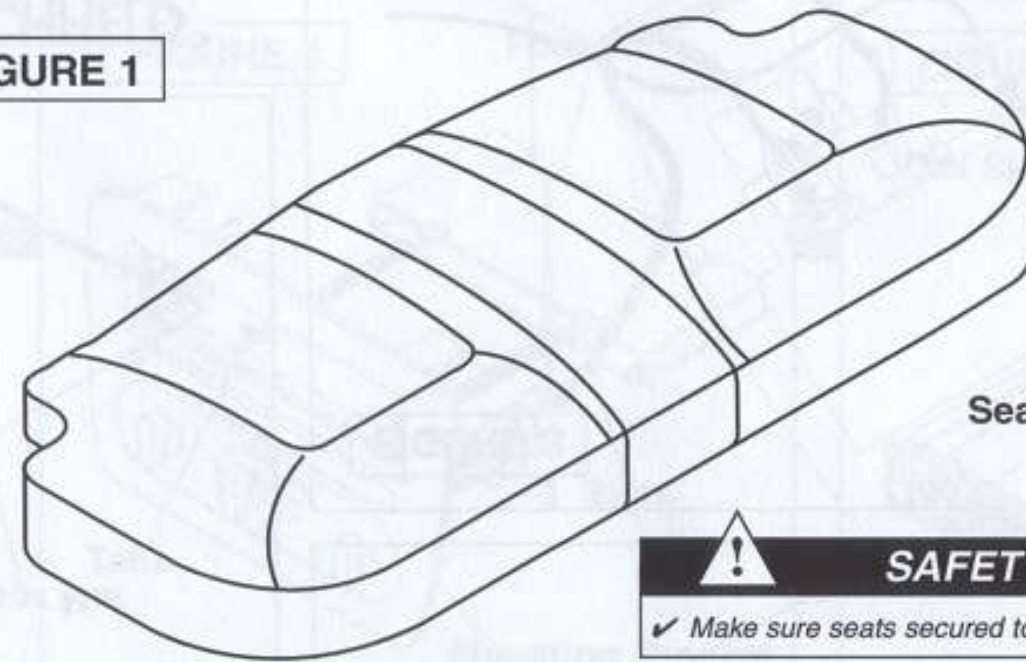

Seat Bottom Cushion



SAFETY CHECK

✓ Make sure seats secured to manufacturers specifications.

FIGURE 2

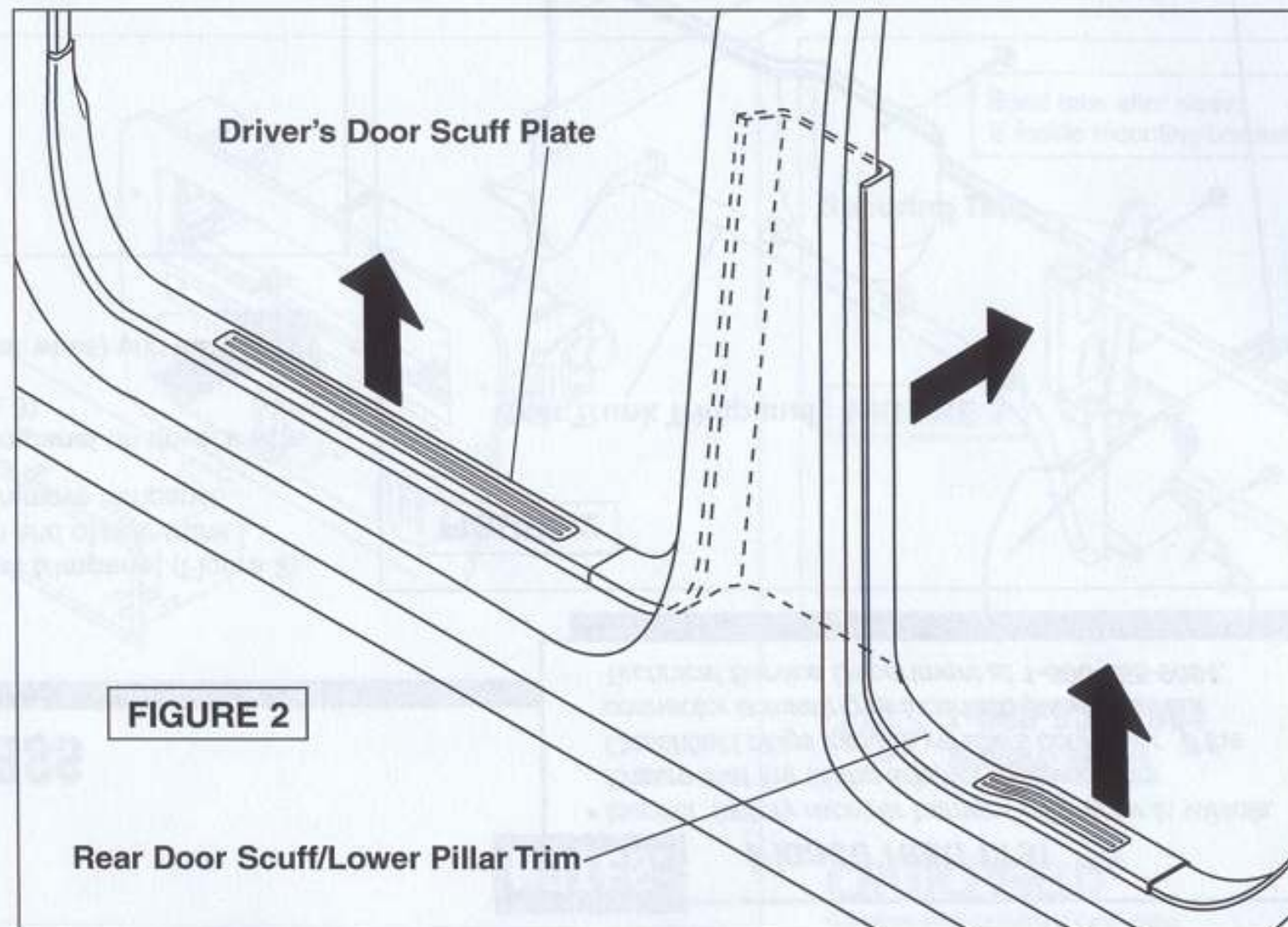

Driver's Door Scuff Plate

Rear Door Scuff/Lower Pillar Trim

Receiver Installation

NOTES:

Please read first

- Inspect factory receiver harness connector in vehicle. Ensure that the wiring adaptor received from Crutchfield plugs into the vehicle's connector. If the connector is missing or incorrect, please call our Technical Service Department at 1-800-955-9094.

1. Cut off excess length of wires from adaptor harness. **Important:** Leave enough length so that wiring connections can be easily made. **Do not** cut off any excess antenna lead.
2. Place a covering such as an old piece of carpet, under receiver location to protect car interior during soldering.
3. Make wiring connections following instructions supplied with installation kit.

Important: The *Orange (illumination)* wire from the blue harness on the back of the receiver mounting bracket, must be spliced into the *Blue/White wire from the ashtray light*. **Note:** The wire is located in a 6-pin harness that is either plugged into ashtray assembly or is connected to an intermediate harness that hangs to the left of the receiver cavity. **Do not** splice into the *Blue/White wire from the cigarette lighter* located on the right side of the cavity. Make splice as shown (See Inset, steps 1 through 4).

4. Fold up excess antenna lead and tape into a bundle.
5. Hold **receiver/climate control assembly** near dash. Plug antenna lead into rear of receiver and harness from assembly into factory harness. Plug climate control harnesses into switches.
6. Align side spring clips with guides in dash and slide assembly into dash opening until it locks into place.
7. Reconnect battery and test receiver operation.

- An aftermarket receiver cannot be installed in Taurus and Sable vehicles equipped with digital climate control units.

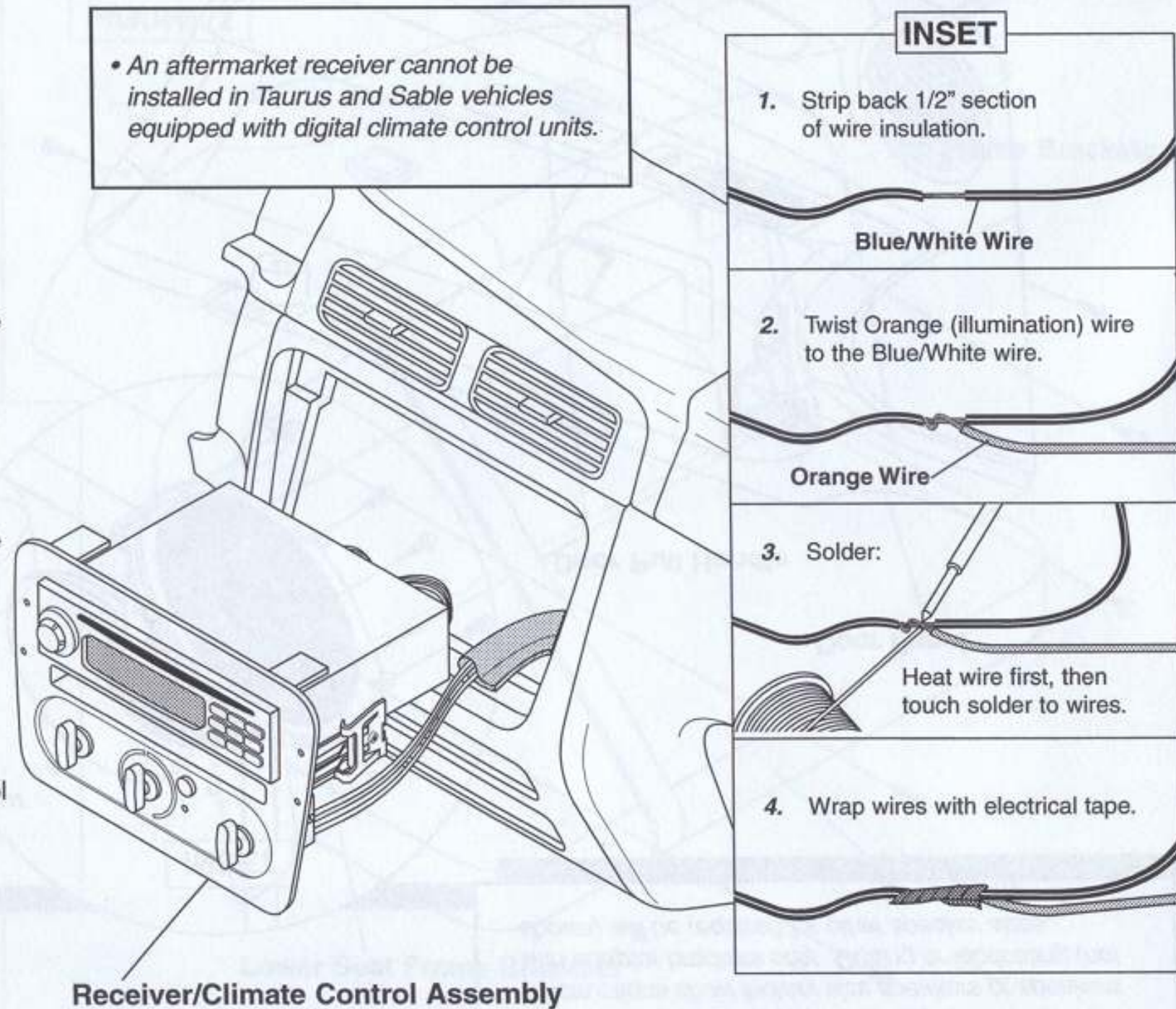

019 0137

Door Speakers

NOTES:

Please read first

- Instructions show factory size speakers or speakers with adaptor brackets only. Cutting or fabricating (not shown) will be required for other speaker sizes.

1. Remove two (2) phillips screws located under **door pull handle**.
2. Remove one (1) phillips screw from front center edge of **door panel**.
3. Remove two (2) phillips screws from bottom edge of door panel.
4. Remove two (2) phillips screws from rear edge of door panel.
5. Pry out top and rear edges of door panel to release five (5) retaining clips. Pull door panel, disconnect electrical connectors and remove panel.
6. Remove four (4) 1/4" screws securing speaker to door. Remove and disconnect speaker.
7. Secure speaker wiring adaptor of replacement speaker to connector in vehicle.
8. Secure replacement speaker to door using screws previously removed (Inset).
9. Test speaker operation and reassemble door by reversing disassembly steps.

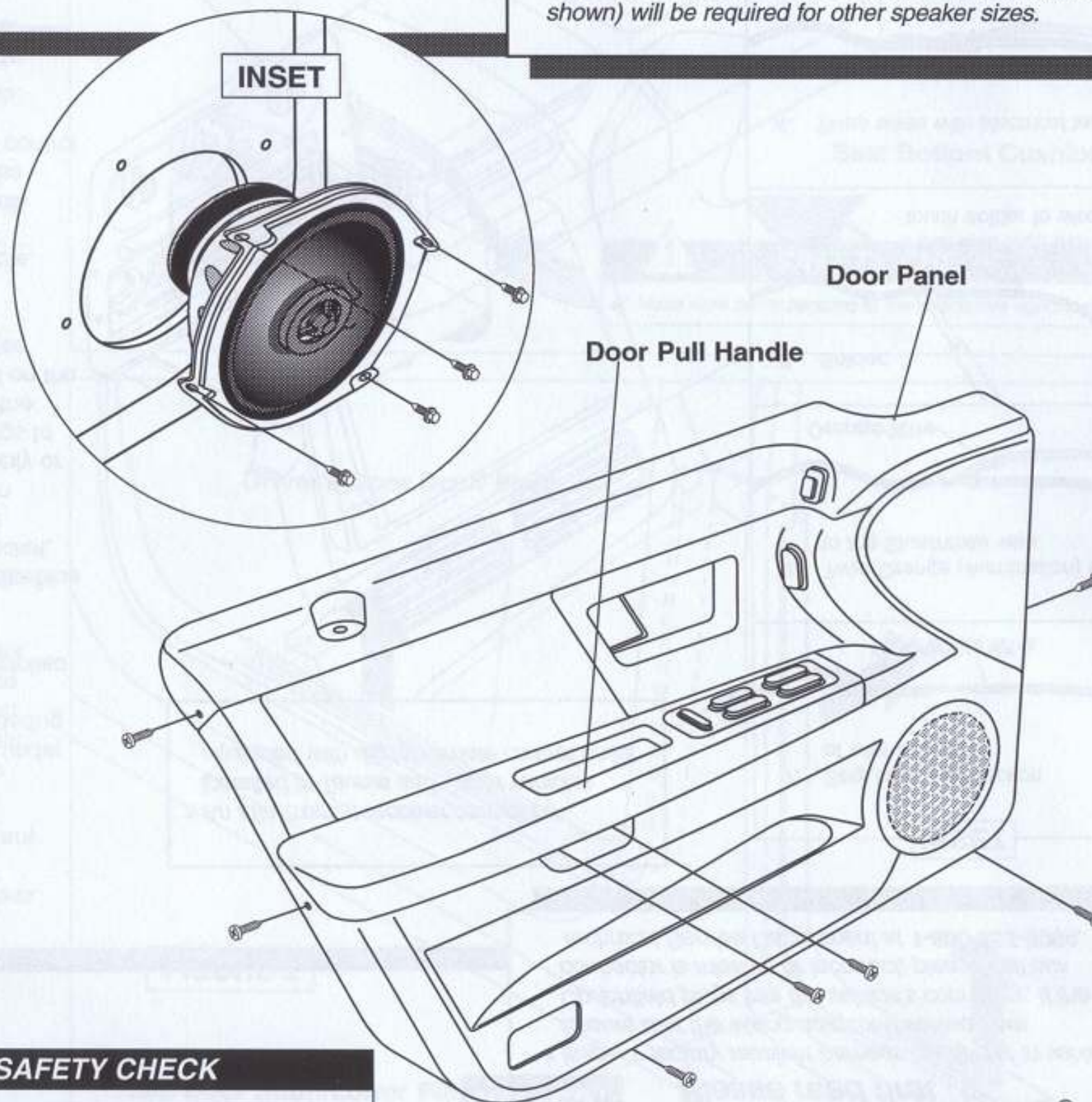

SAFETY CHECK

- ✓ Check that wires do not interfere with window operation.
- ✓ Test window and door lock operation.



1-800-955-9094
Technical Service

CRUTCHFIELD®

Copyright 2005 Crutchfield Corporation

019 0137

Rear Speakers -- Sedan

NOTES:

Please read first

- Instructions show factory size speakers or speakers with adaptor brackets only. Cutting or fabricating (not shown) will be required for other speaker sizes.

1. Pull up front edge of **seat bottom** to release hooks and remove seat bottom (Figure 1).
2. Fold down seat back. Remove two (2) 1/2" bolts from bottom of **lower seat frame brackets** and two (2) 1/2" bolts from **top frame brackets** (Figure 2).
3. Lift upper seat cushion and set it against front seats. **Note:** Seat belt will remain in guide.

Continued on the next page.

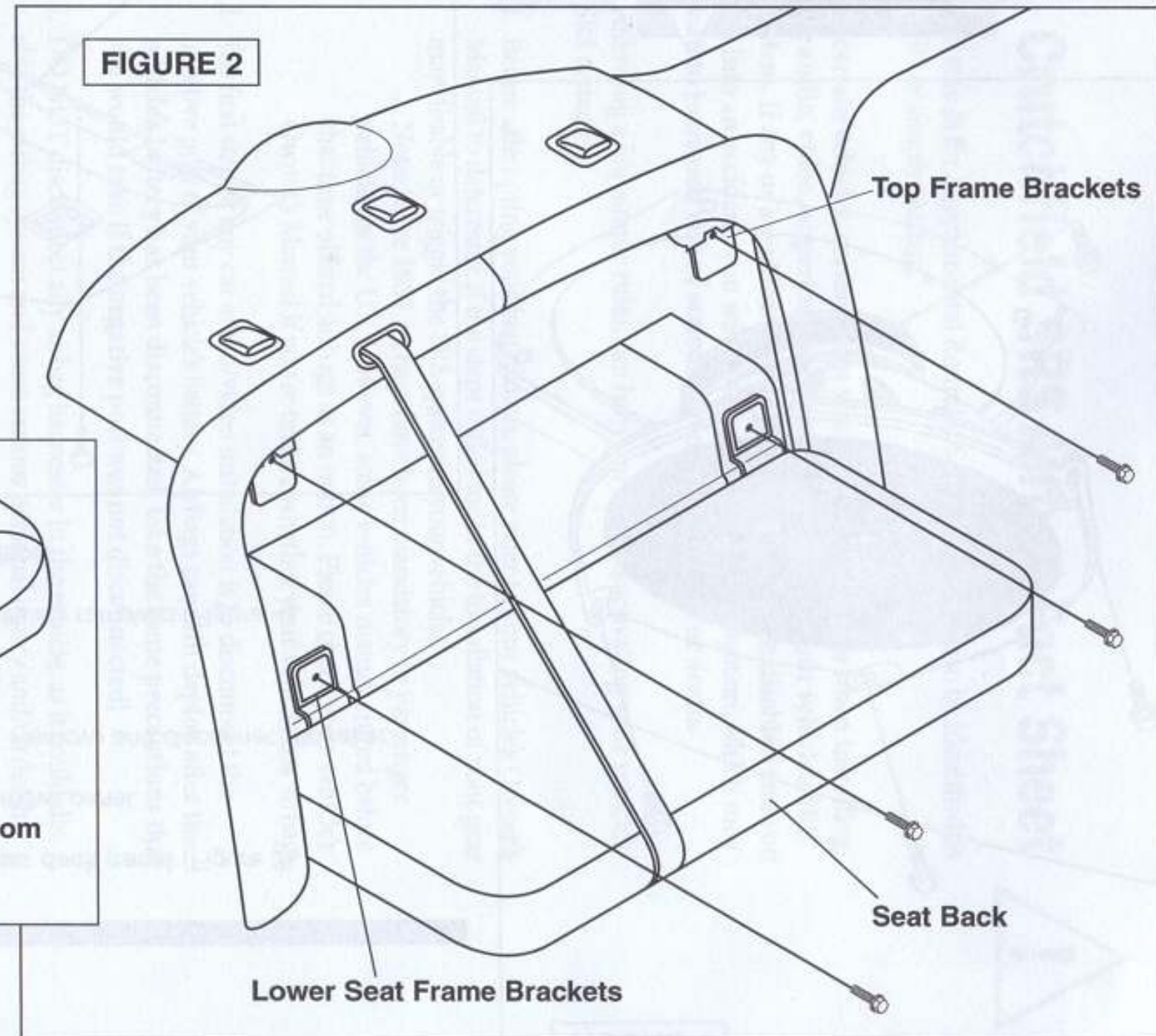
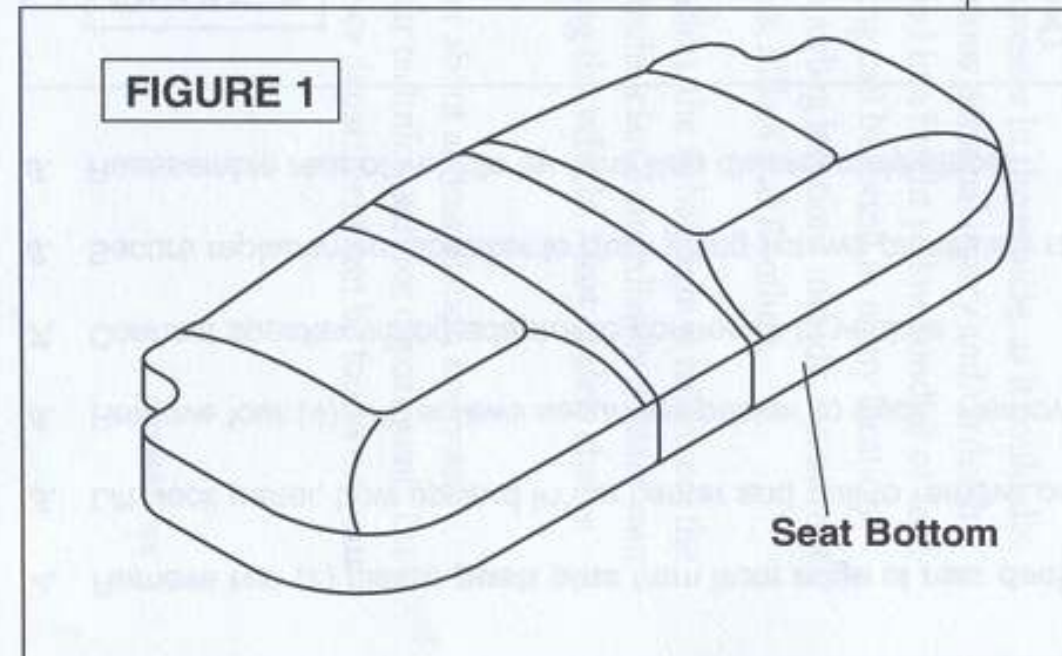

1-800-955-9094
Technical Service

CRUTCHFIELD[®]

Copyright 2005 Crutchfield Corporation

019 0137

Rear Speakers (continued)

4. Remove two (2) plastic **push pins** from front edge of **rear deck panel** (Figure 3).
5. Lift deck panel, bow upward in the center and pull to remove panel.
6. Remove four (4) 1/4" screws securing speaker to deck. Remove and disconnect speaker.
7. Connect speaker wiring adaptor to connector in vehicle.
8. Secure replacement speaker to deck using screws previously removed (Figure 4).
9. Reassemble rear of vehicle by reversing disassembly steps.

FIGURE 3

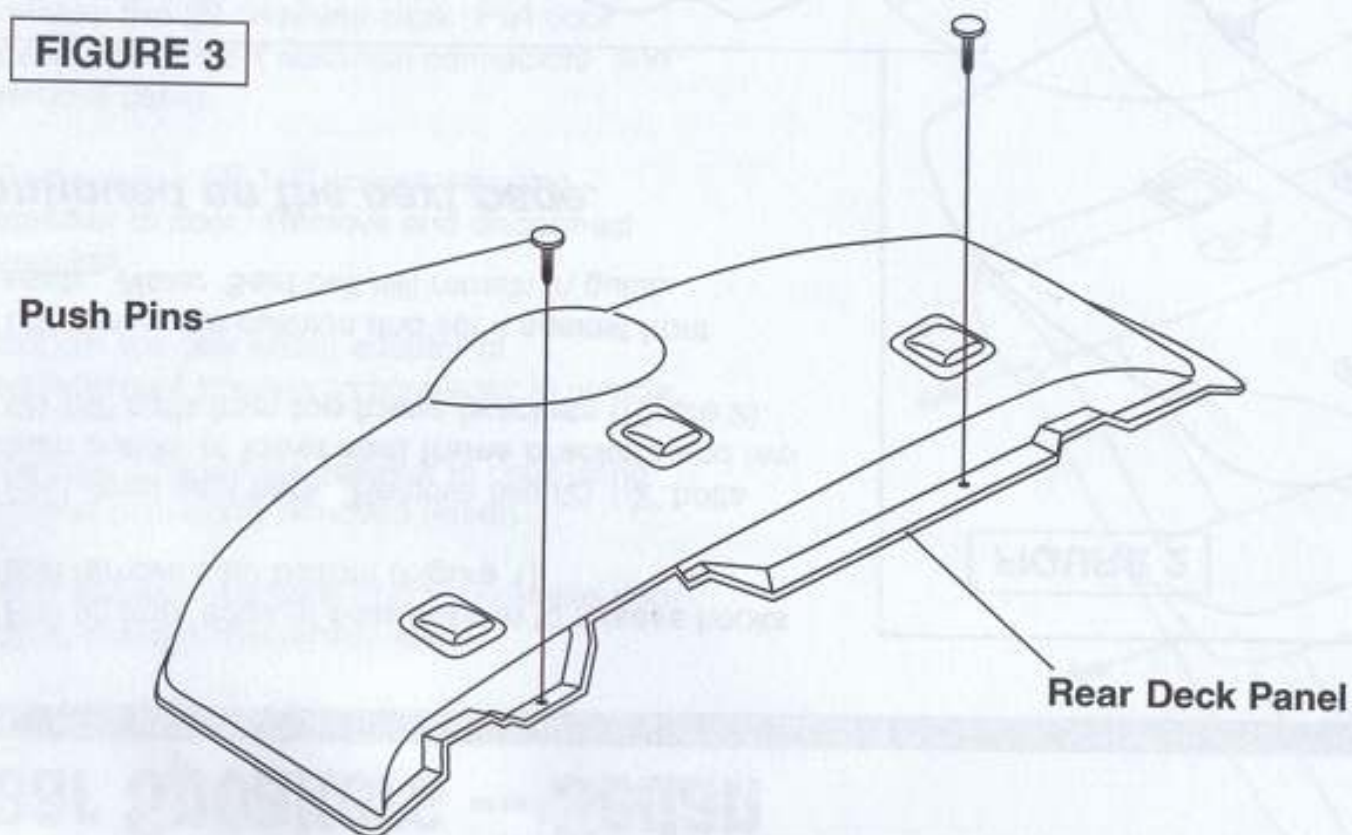
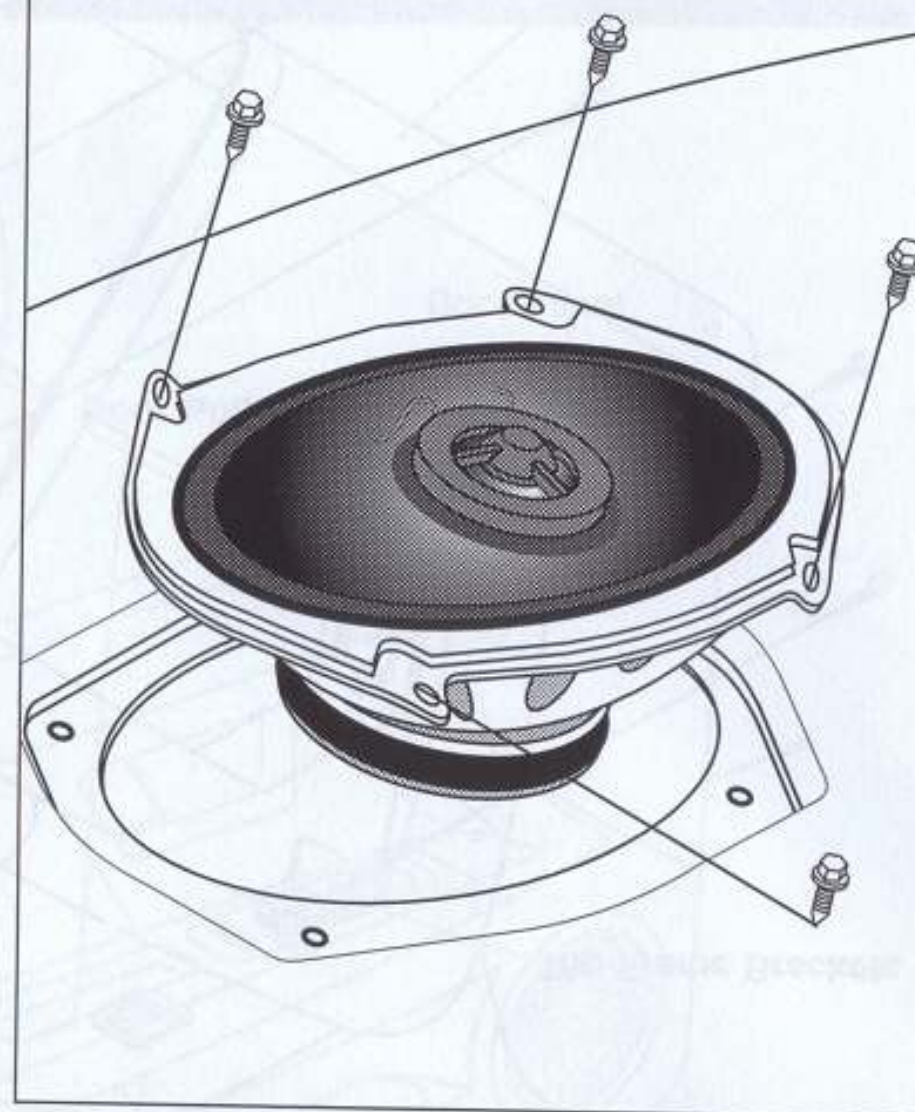

FIGURE 4



! SAFETY CHECK
✓ Make sure seats are secured to manufacturers specifications.



1-800-955-9094
Technical Service

CRUTCHFIELD®

Copyright 2005 Crutchfield Corporation